

# veritas®

## Iron Edge-Trimming Plane

---

The edge-trimming plane is used for final trimming cuts on jointed boards to ensure smooth edges exactly 90° to the face. The ductile cast iron body is shaped to fit comfortably in the hand, and the carefully machined blade bed and cap iron combine to produce chatterfree cutting. The 12° bed angle and 30° blade skew make the plane suitable for working on end grain as well as long grain. The 1/8" (0.125") thick blade, available in A2, O1 or PM-V11® tool steel, is 1 1/4" wide so that a full 1" cut can be made. Depth adjustment is fast and accurate via the thumb wheel, and set screws along the side prevent the blade from shifting when knots are encountered. This plane is drilled to allow a wooden wedge to be fixed to the fence for cutting controlled bevels.

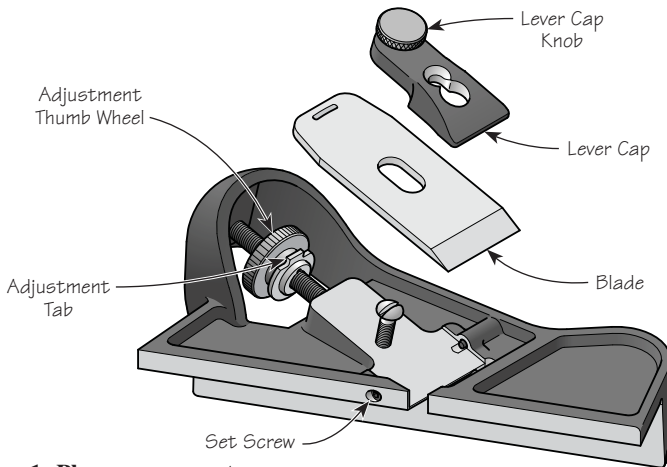

**Figure 1: Plane components.**

### Installing the Blade

 **Caution:** Be aware that the blade is sharp; careless handling can result in serious injury. Remove the lever cap, then rotate the adjustment thumb wheel so that the adjustment tab is facing up (see **Figure 1**). Place the blade (bevelled edge up) over the oval-head screw and onto the bed, taking care to insert the adjustment tab into the slot in the blade.

### Blade Sharpening

The edge plane has a bed angle of 12° and the blade comes ground at an angle of 20°. Since the blade is used bevel up, the effective cutting angle will be 32°.

The 20° blade is ideal for long-grain work and for fine trimming work on end-grain softwood such as pine. End-grain work on hardwoods such as maple will require a 25° bevel; ring-porous hardwoods such as oak may require a 30° bevel to prevent blade edge failure. Simply hone a micro-bevel to the desired angle.

## Blade Adjustment

To initially set the blade, place the plane on the straight edge of a piece of wood (e.g., a scrap of stock). Lightly clamp the blade with the lever cap knob and advance the blade until it just touches the wood.

Flip the plane to a sole-up position, then sight along the sole to ensure the blade edge is parallel to the sole. Adjust as required by tapping either side of the blade at the back. Clamp fully (a quarter turn should be ample – **do not overclamp**) and take a test cut. If all is well, advance the set screws on either side until they just touch the blade, not to clamp it but to create a guide so that you do not have to be concerned about the blade shifting sideways.

You will quickly get accustomed to setting blade depth by sighting along the sole, but for very fine shavings, you will still need to take test cuts.

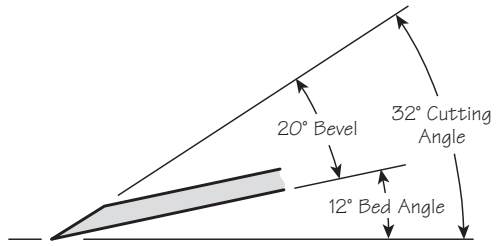

Figure 2: 20° blade geometry, as supplied.

## Using the Plane

The plane may be pushed forward in the usual manner. Many people, however, find the plane more convenient to use by pulling it toward them.

The plane is well suited to finishing the ends of boards after sawing. On end grain, be sure to plane from both edges toward the center to avoid splintering the edges of the board.

## Bevels

The edge plane can be used to make controlled bevels, such as required for boatbuilding. Simply fasten a wooden wedge to the plane using two #8 wood screws (not included) through the holes machined in the plane body, as shown in **Figure 3**.

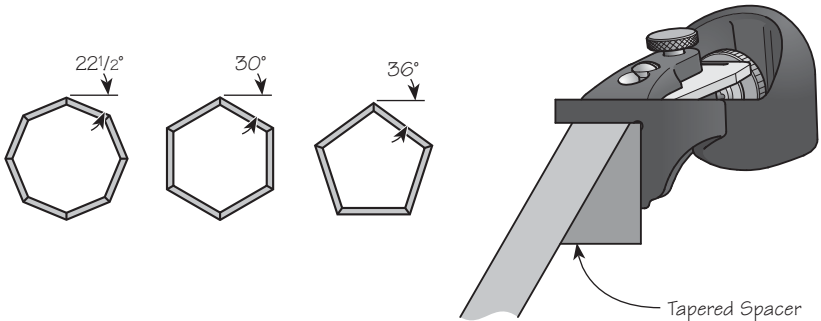

Figure 3: Cutting bevels.

## Care and Maintenance

The body of this plane is ductile cast iron and comes treated with rust preventative. Remove this using a rag dampened with mineral spirits. Clean all machined surfaces.

We recommend that you initially, then periodically, apply a light coat of silicone-free paste wax to seal out moisture and prevent rusting (as well as act as a lubricant for smoother planing). Wipe off any wood dust from the surfaces that you will be waxing, apply a light wax coating, let dry, then buff with a clean soft cloth. At the same time, the solvents in the wax will remove any harmful oils left from your fingers that can lead to corrosion.

If storage conditions are damp or humid, the plane should, in addition to the treatment outlined above, be wrapped in a cloth or stored in a plane sack. This precaution will also guard against dings and scratches.

## Accessories

**05P03.02** A2 Blade

**05P03.52** O1 Blade

**05P03.72** PM-V11® Blade